



P.A. – S.p.A. – EQUIPAGGIAMENTI TECNICI DEL LAVAGGIO

VIA MILANO, 13 – CASELLA POSTALE 115 – 42048 RUBIERA (REGGIO EMILIA) – ITALY
 Tel. +39 0522 623611 – Fax. +39 0522 629600 – R.E.A. RE 156319 – R.I. RE11535 – Mecc. RE 013446
 C.F. e P. IVA 01035950359 – Cap. Soc. i.v. € 750.000,00 – Codice Identificativo C.E.E. IT 01035950359
 ART. 2497 – BIS C.C. DIREZIONE E COORDINAMENTO BENETTI srl R.I. TRIB. DI RE 01480690351
 Web: <http://www.pa-etl.it> – E-mail: info@pa-etl.it



PULSAR 4 R – With Micro Switch



Recycled water version

Technical manual: **E 286**

Unloader with integrated micro switch, which is actuated by the piston of the unloader when a pre-determined, pre-set pressure level is reached. The piston opens or closes the electric control. At gun closure, the water flow is discharged in bypass reducing the pressure in the system upstream of the unloader.

DN 10



- **60.0010.60** 3/8" F Bsp Blue spring
 - Dynamic seals made up of O-ring and runner in teflon.
 - Optimized internal passages that guarantee reduced pressure loss.
 - Antirotation device of the piston positioned inside the valve and obtained by an hexagonal sector of the piston itself.
 - O-rings of the fittings positioned upstream to the thread : no risk of fittings ejected in case of overpressure.
 - Double bypass connection.
 - Isolating class IP55
 - Electrical switch controlled mechanically by the unloader piston
- 2 positions:
1. Unloader working in pressure
 2. Unloader with whole water flow in by-pass

TECHNICAL FEATURES										
Construction Material				Brass Body, inner parts in stainless steel						
Rated Temperature (1)				90°C						
PART NO.	RATED PRESSURE		PERMISSIBLE PRESSURE		MIN. ADJUSTABLE PRESSURE		% PRESSURE DECREASE FOR VALVE RESET (2)	MAX FLOW	WEIGHT	INLET OUTLET BYPASS
	bar	MPa	bar	MPa	bar	MPa	%	l/min	g	
60.0010.60	280	28	310	31	72	7.2	30	40	700	3/8" F Bsp

1) The valve has been designed for a continuous use with water at a temperature of **60°C (140°F)**. It can work for short periods with water at the maximum temperature of **90°C (195°F)**.

2) When the valve is in bypass mode, this is the decrease of pressure that has to occur in the circuit downstream of the valve, in order that the valve can restore the working pressure in the system. The indicated figure is expressed as a percentage of the pressure setting (working pressure).

At gun closure, a pressure increase occurs in the circuit downstream of the valve. This pressure increase is used to activate the valve and discharge all the flow in bypass. The value of the pressure increase cannot be calculated. It depends on the correct setting of the valve (see PRESSURE ADJUSTMENT/SETTING) and on the layout of the system: flow rate, working pressure, length and characteristic of the tubes, closing time of the gun.

DIMENSIONAL DRAWING

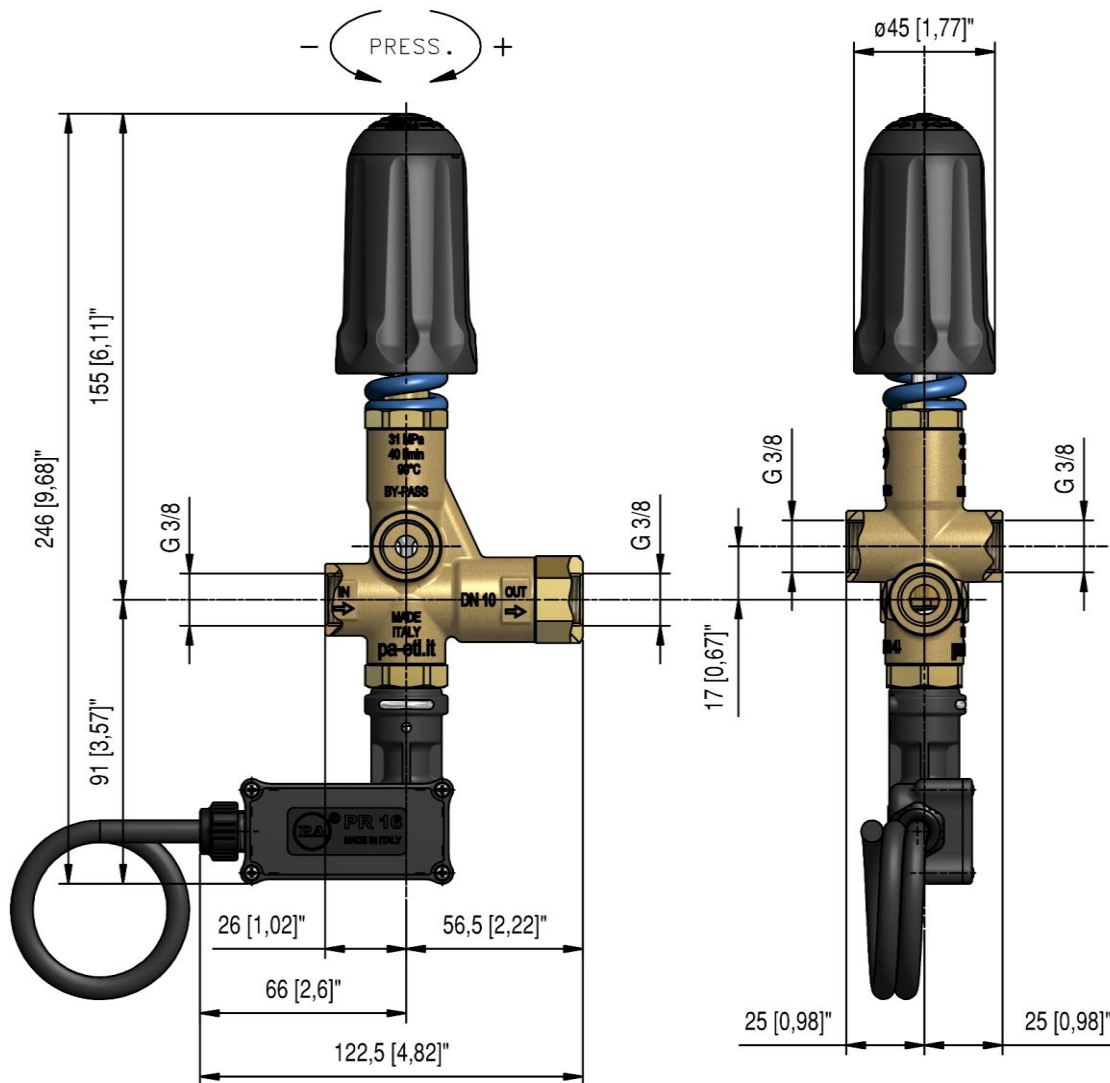

INSTRUCTIONS

DESCRIPTION

The valve has an inlet ports with Bsp 3/8" F thread (3/8"NPT F)
 The valve has an outlet port with Bsp 3/8" F thread (3/8"NPT F) .
 The valve has also two bypass ports with Bsp 3/8" F thread (3/8"NPT F) .
 The valve is available in two different versions: with and without the plastic adjustment Knob.

SELECTION

This product is intended to be incorporated on a finished machine. This product is to be utilized with clean fresh water, or with a slight addition of standard detergents. For use involving different or corrosive liquids, contact the PA Technical department. Appropriate filtration should be installed when using impure liquids. Choose the valve in line with the working data of the machine where to be installed (permissible pressure, maximum flow rate and rated temperature of the system). In any case, the pressure of the machine must not exceed the permissible pressure imprinted on the valve.

OPERATION

The valve regulates the pressure of the system by altering the flow discharged by the bypass. The adjustment is carried out by changing, by means of a piston, the position of a ball that partially shuts the bypass opening. At gun closure, a check valve closes and isolates the part of the circuit downstream of the valve: the pressure increase that remains trapped is used to activate the complete opening of bypass. All the flow supplied by the pump is therefore discharged at low pressure through the bypass and the pump works at low pressure.

INSTALLATION

This item is to be installed on a finished machine. On a system that produces hot water, this accessory must be fitted upstream of the heat generator. On a system that generates hot water, On a system that produces hot water, it is advisable to fit in accessories that limit the accidental increase of fluid temperature.

Always install a safety valve.

It is recommended to use a nozzle with a size that, at gun opened, allows to discharge from the valve bypass at least 5% of the flow supplied by the pump in order to obtain a constant pressure value, and an easy adjustment and to avoid troublesome pressure spikes at gun closure.

If the nozzle wears out, the working pressure decreases. To reset the pressure back to work level, it is necessary to replace the worn out nozzle. When a new nozzle is fitted, re-setting of the system to its original working pressure is necessary.

Electrical installation has to be carried out by qualified personnel only.

WARNING: Always assure adequate grounding to the electric device.

ELECTRICAL FEATURES OF THE MICRO SWITCH

Max Rated Voltage:	250 V
Breaking switch::	16 (A) – resistive load - 6 (A) – inductive load
Cable length:	1200 mm – Electric wire : 3 x 1 mm
Max.amperage cable::	10 A
Environment temperature:	75 °C – Type of action: 1C
Lifetime electrical component:	50.000 commutations, T.85°C, a 250V a.c.in line with CEE 24- VDE 0630
Pollution situation of the device control:	High

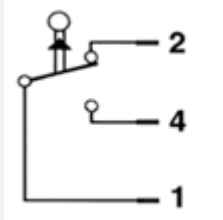

WIRING DIAGRAM

1) RED wire - 2) BLUE wire - 4) BROWN wire

TUBAZIONI SCARICO E ADDUZIONE ACQUA

Lo scarico del bypass può essere rimandato alla bocca di aspirazione della pompa oppure può essere inviato in un serbatoio; in tal caso è consigliabile che il serbatoio sia munito di setti separatori per ridurre eventuali turbolenze e bolle d'aria, generate dall'immissione del flusso di bypass, che potrebbero essere dannose per la pompa.

DISCHARGE SYSTEM AND WATER ADDUCTION

The bypass discharge can be sent back to the pump intake or returned into a tank; in such case it is adviseable that the tank be fitted with deflectors to reduce eventual turbulence and air bubbles generated by the immission of the bypass flow which could be harmful for the pump.

PRESSURE ADJUSTMENT/CALIBRATION

The desired working pressure must be adjusted with the system running and the gun opened. Adjust the pressure by screwing or unscrewing the adjustment screw/knob. The operation is easier if the correct nozzle has been chosen (see paragraph "installation"). When screwing the screw/knob a consequent pressure increase must be matched. If, before reaching the desired pressure, there is no pressure increase when screwing the screw/knob, do not insist but check the correct ratio nozzle/flow rate – pressure and, if necessary, fit a nozzle with an inferior size. In the knob version, it is possible to set up the minimum working pressure with the provided locknut (pos.18).

ATTENTION: The nut in position 12 is a mechanical security device that limits the maximum pressure; it must absolutely not be removed.

TROUBLESHOOTING:

ISSUE	PROBABLE CAUSE	SOLUTION
Frequent valve recycles	Damaged check valve O-ring Leaking connections Restricted bypass or too small diameter of the bypass hose	Replace Check or renew Clean or adapt passage diameter
Valve does not reach pressure	Piston O-rings worn out Material between seat and shutter Seat worn out Nozzle worn out Incorrect choice of nozzle	Replace Clean the seat Replace Replace Fit nozzle with lower size
High pressure spikes at gun closure	There is not a min of 5% of total flow discharged in bypass Excessive flow in bypass Adjustment with spring totally compressed	Reset correctly Change type of valve or adjust passages Loosen adjustment screw/knob and eventually fit nozzle with lower size
Valve does not discharge at low pressure at gun closure	Jammed check valve Material matter on check valve	Clean or replace Clean
Lack of electric signal	Disconnected Wires Control piston broken	Reconnect Adjust nut and ball holder

MAINTENANCE

STANDARD: every 400 working hours, control and lubricate the seals with water resistant grease.

SPECIAL: every 800 working hours, control the wear of the seals and internal parts and if necessary, replace with original PA parts taking care, during installation, to lubricate with water resistant grease.

Maintenance has to be carried out by Specialized Technicians.

The Manufacturer is not to be considered responsible for damage as a result from incorrect fitting and maintenance.

REGULATIONS : see Norm Manual.

The accessory hereby described bears the CE marking in accordance with the standards and directives published in the Declaration of conformity.

For a correct utilization, follow the directions described in this manual and re-print them on the Use and Maintenance manual of the machine. If needed, ask for the original Conformity Declaration for the chosen accessory. The present manual is valid for all unloader valves named **PULSAR 4 WITH MICROSWITCH**.

Technical data, descriptions and illustrations are indicative and liable to modification without notice.

Instruction manual, maintenance, installation, spare parts.	n. 12.9286.00
--	---------------